

GENIUS MT 12-21

GN 12 X 2/1

Combi steamer, gas, right hinged



HIGHLIGHTS

MT TECHNOLOGY:

- 7" MultiTouch Display
- Climatic®MT
- Last®20
- Quick Set
- Multi Cooking
- Quick Mode
- autoclean® MT
- 9 operating modes
- 10 fan speed levels
- Steptronic®
- Multi-Eco-System
- Multi-point core-temperature sensor
- SPS®: Steam Protection System

GENIUS MT 12-21 GN 12 X 2/1

DIMENSIONS

Width x depth x height in mm: 1310 x 1086 x 1490

Weight: 350 kg

Weight with packaging: 450 kg

Number levels: 12 x GN 2/1

Distance between levels: 67 mm

ELECTRICAL SUPPLY

Voltage: 230V/ 1 N AC

Connection load: 35,00 kW

Rated current: 4,5 Amp

Protection: 1 x 16 Amp

Res. current circuit breaker, frequency converter 1PH: 16Amp

Recommended cross section: 1,5 qmm

Noise emission: < 70 dB (A)

Article number:

EL1213001-2X

SAFETY CLEARANCE

Rear: min. 50mm

Right: min. 50mm

Left: min. 50mm

Minimum distance to heat sources: min. 50mm

LOADING CAPACITY

GN 2/1: 12

EN / BN*: 5

Plates max Ø32 cm: 18

*Serial-hanging racks GN, EN/BN hanging racks available with accessories

WATER CONNECTION

Water supply/dim: 2 x G 3/4" A

Flow pressure: 2 - 6 bar (200 - 600 kPa)

DRAIN SYSTEM

Version: permanent connection (rec.) or funnel waste trap

Type: DN50 (min. Ø internal: 46mm)

Slope for waste water pipe: min. 3%

WATER QUALITY

General requirement: drinking water

Total hardness: ≤ 3°dh / 70 - 125 ppm / 7-13° TH / 5-9 °e

pH-value: 7,0 - 8,5

Cl (chloride): max. 60 mg/l

Cl₂ (free chlorine): max. 0.2 mg/l

SO₄²⁻ (sulphate): max. 150 mg/l

Fe (iron): max 0.1 mg/l

Temperature: max. 40°C

Electrical conductivity: min. 20 µ S/cm

Water pressure: 4 bar (2 - 6 bar)

WATER CONSUMPTION

Soft water: 25 l/h (at 4 bar)

Hard water: 55 l/h (at 4 bar)

HEAT EMISSION

latent: 12,6 MJ/h, sensitive: 10,71 MJ/h

STANDARDS

Safety: VDE - UL-CSA, SVGW, WRAS

Protection: IPX 5

Built according to: DIN 18866-2



GENIUS MT 12-21 GN 12 X 2/1

STANDARD FEATURES

9 operating modes from 30°C to 300°C

7" Multitouch-Display (resistiv)

autoclean®MT

Quick Set

Eloma live steam system

Steptronic®

Climatic®MT

Fan speed in 5 levels - each one can be pulsed

Autoreverse fan wheel for even results

e/2 - energy savind mode

Start time setting up to 24h

400 programme spaces with 20 steps each

Favourites marking and filtering

Quick Mode

HACCP/LMHV data logging and display

Last*20

Multi-point core-temperature sensor

Active-Temp

Safety door lock

Integrated spray hose

Temperatures from 30°C to 300°C

SPS®: Steam protection system

Manual steaming

Multi-Eco-System

Delta-T cooking

LT-cooking

Regeneration mode

Multi Cooking

OPTIONS

External sous-vide probe

External core temperature probe

Ocean version

Special voltages

Connection energy optimisation

LAN-connection

ACCESSORIES (EXTRACT)

ProConnect data management software

Vario-hanging racks for GN 1/1 and BN 46

Mobile tray rack, push-in-frame

Mobile plate rack

SmokeFit smoking device

Trays, grids and pans



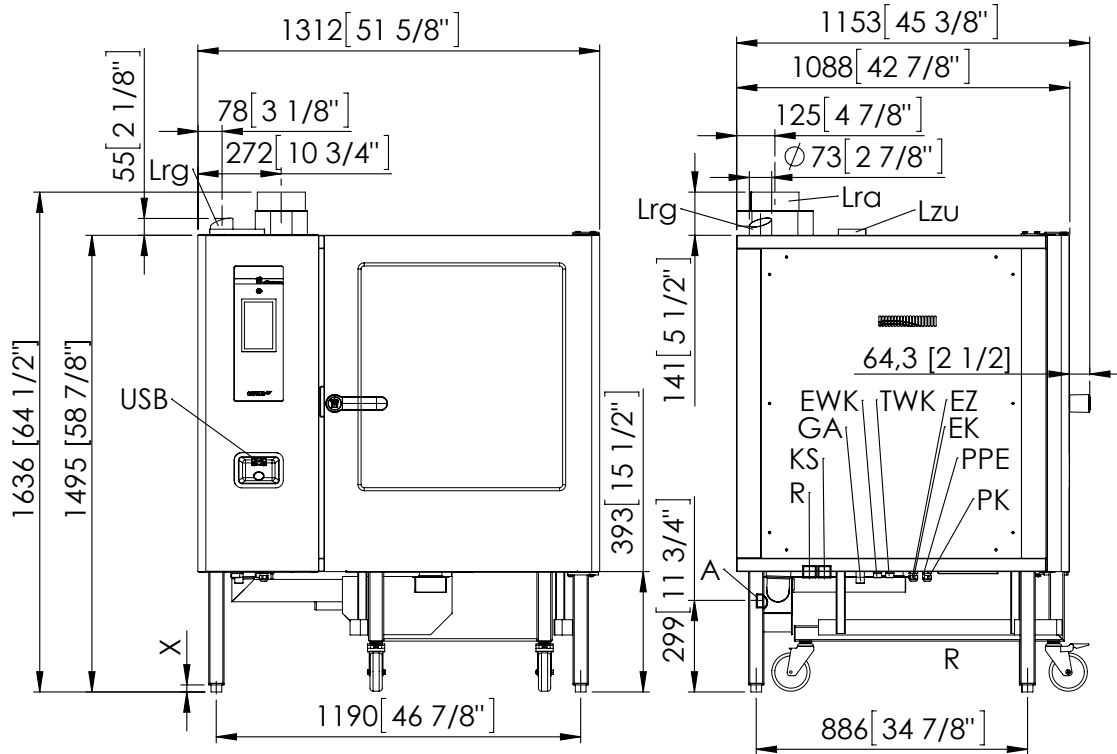

- Lzu Supply air opening
- Lrg Exhaust air pipe
- A Connection for waste water line (DN2")
- EWK Connection for soft water (BSP3/4") (US:GHT 3/4")
- TWK Connection for hard water (BSP3/4") (US:GHT 3/4")
- EZ Power supply
- EK Communications connection (e.g. RS232, LAN)
- USB USB port
- PPE Connection for potential equalisation
- PK Floating contact (optional)
- EZEo Power optimization
- X Feet, adjustable (+/- 3/8")
- R Connection for cleaner
- KS Connection for rinse

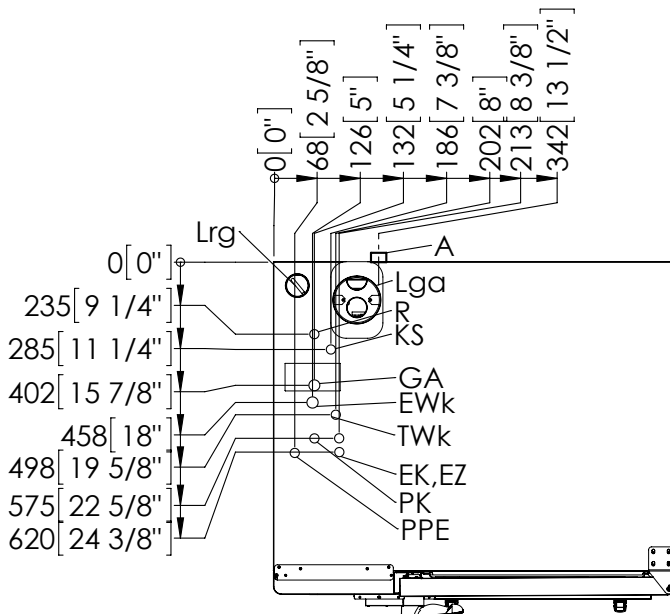

Eloma GmbH | Otto-Hahn-Str. 10 | 82216 Maisach/Germany
 Phone: +49 8141 395-0 | Fax: +49 8141 395-130
 Mail: sales@eloma.com
 eloma.com



CUSTOMER SERVICE
 P. +49 8141 395-188
 F. +49 8141 395-130
 sales@eloma.com